

# Large Display ORP Pen

**850053**

SPER  
SCIENTIFIC

---

Environmental Measurement Instruments



**EASTERN**  
**ENERGY**

[www.eastern-energy.net](http://www.eastern-energy.net)

email: [info@ete.co.th](mailto:info@ete.co.th)

## Large Display ORP Pen - 850053

Copyright ©2015 by Sper Scientific  
ALL RIGHTS RESERVED. Printed in the USA

The contents of this manual may not be reproduced or transmitted in any form or by any means electronic, mechanical, or other means that do not yet exist or may be developed, including photocopying, recording, or any information storage and retrieval system without the express permission from Sper Scientific.



[www.eastern-energy.net](http://www.eastern-energy.net)  
email: [info@ete.co.th](mailto:info@ete.co.th)

## **TABLE OF CONTENTS**

1. INTRODUCTION . . . . .	3
2. MATERIALS SUPPLIED. . . . .	3
3. FRONT PANEL DESCRIPTION . . . . .	4
4. OPERATING INSTRUCTIONS . . . . .	5
5. MEASUREMENT PROCEDURE . . . . .	5
6. BATTERY REPLACEMENT . . . . .	6
7. TROUBLESHOOTING . . . . .	7
8. SPECIFICATIONS. . . . .	8
9. WARRANTY . . . . .	8

## **INTRODUCTION**

This is a simple and easy to use IP65 waterproof ORP Pen. It features a large display for easy reading, data hold, low-battery indicator and auto power off.

## **MATERIALS SUPPLIED**

Meter  
Batteries  
Instruction Manual

## FRONT PANEL DESCRIPTION

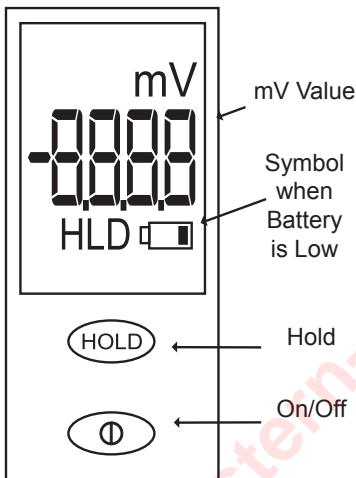

### **Please Note:**

*The ORP pen electrode must always be stored wet. The sponge included in the protective cap must always be saturated with KCl. Neglect to store the OPR pen correctly will void the warranty.*

## NOTE REMOVING PROTECTIVE CAP:



*Hold the blue ring firmly in place with one hand, rotate the semi-transparent bottle 180° ~ 360° clockwise. This will loosen the gasket to allow you to pull the cap off. Reverse the procedure to put the cap back on.*

## OPERATING INSTRUCTIONS

1. Remove the protective cap.
2. Clean the electrode with de-ionized/distilled water.  
Note: Crystals may form in the cap and these can be soaked or rinsed away. Do not touch or rub the glass bulb.
3. Before first use, after extended storage, or if the electrode is contaminated soak the electrode in KCl (potassium chloride) solution for 10~30 minutes, then rinse with deionized/distilled water.

## MEASUREMENT PROCEDURE

1. Remove the protective cap and clean the electrode with de-ionized/distilled water. Do not touch the glass bulb.
2. Press **Ⓚ** >1 sec to turn on the unit.
3. Dip/stir the electrode into the sample.
4. The mV value is displayed.
5. “- -” is displayed when the mV sample is out of range.
6. During measurement, press HOLD to freeze the reading on the LCD. “Hold” is displayed. Press HOLD again to return to normal measurement.
7. The ORP Pen automatically shuts off after 20 minutes of inactivity. To disable this feature, start with the unit off, then simultaneously press the **Ⓚ**

and HOLD buttons. Release both buttons when “n” is displayed. The unit returns to measurement mode.

8. After use, turn off the unit and rinse the electrode.
9. Protect the electrode's lifespan by adding a few drops of KCl (potassium chloride) solution into the protective cap before storage. Always keep the protective cap on when the unit is not in use.

## **VERIFY READINGS**

*To verify the readings of the ORP pen, follow the instructions below.*

1. Press  $\text{Ⓢ}$  >1 sec to turn on the unit.
2. Put the electrode in buffer solution of pH 7 with saturate quinhydrone. After stirring, the mV reading should be  $86 \pm 15$  mV.
3. Rise the electrode with de-ionized/distilled water.

## **BATTERY REPLACEMENT**

1. Replace all 4 LR44 batteries when the low battery icon is flashing, or when troubleshooting fails.
2. Unscrew the cover and install the batteries with the flat positive (+) side facing the springs.
3. Do not remove the black O-ring.

4. Remove the batteries when the unit is not in use for an extended period.

## **TROUBLESHOOTING**

1. If there is no display, or you have erratic readings after having soaked the electrode in KCl (potassium chloride) solution for at least 30 min prior to verifying the readings, check the continuity of the batteries by removing them for 1 minute, then reinsert.
2. Slow Response: Soak the electrode in KCl (potassium chloride) solution for 10-15 minutes, then rinse with distilled/de-ionized water.
3. “E02” or “E03” displays when the ORP reading is out of range (either too high or too low).
4. No Display: Be sure to press **⓪** for at least one second. If the problem persists, see Battery Replacement (previous page).
5. If your readings are still erratic after calibration, soak the electrode for 10 to 30 minutes in KCl (potassium chloride) solution.
6. Note: It is normal for the pH value to fluctuate quickly when the electrode is exposed to air and not immersed.

## SPECIFICATIONS

Range	-999 mV ~ 999 mV
Resolution	1 mV
Accuracy	$\pm 4$ mV
Operating Temp.	32 ~ 140°F / 0 ~ 60°C
Operating RH	0 ~ 80% RH
Weight	2.3 oz (65 g) with battery
Dimensions	6½" × 1½" × 1½" (165 × 38 × 38 mm)

## WARRANTY

Sper Scientific warrants this product against defects in materials and workmanship for a period of **1 year** from the date of purchase, and agrees to repair or replace any defective unit without charge. If your model has since been discontinued, an equivalent Sper Scientific product will be substituted if available. This warranty does not cover probes, batteries, or damage resulting from accident, misuse, or abuse. To obtain warranty service, ship the unit postage prepaid to:

### SPER SCIENTIFIC

8281 E. Evans Rd. Suite #103, Scottsdale, AZ 85260

The defective unit must be accompanied by a description of the problem and your return address. Register your product online at [www.sperwarranty.com](http://www.sperwarranty.com) within 10 days.

05/2015