

UVC Light Meter

850010

Instruction Manual

SPER
SCIENTIFIC *Environmental Measurement Instruments*

Rev. 5/2/2012



www.eastern-energy.net

Email: info@ete.co.th

UVC Light Meter 850010

Copyright ©2009 by Sper Scientific

ALL RIGHTS RESERVED

Printed in the USA

The contents of this manual may not be reproduced or transmitted in any form or by any means electronic, mechanical, or other means that do not yet exist or may be developed, including photocopying, recording, or any information storage and retrieval system without the express permission from Sper Scientific.

**SPER
SCIENTIFIC**

Environmental Measurement Instruments

7720 E. Redfield Rd. Suite #7, Scottsdale, AZ 85260
Tel: (480) 948-4448 Fax: (480) 967-8736
Web: www.sperscientific.com

WARRANTY

Sper Scientific warrants this product against defects in materials and workmanship for five (5) years from the date of purchase and agrees to repair or replace any defective unit without charge. If your model has since been discontinued, an equivalent Sper Scientific product will be substituted, if available. This warranty does not cover damage resulting from accident, misuse, or abuse of the product. To obtain warranty service, ship the unit postage prepaid to:

SPER SCIENTIFIC LTD.
7720 E. Redfield Rd, Suite 7,
Scottsdale, AZ 85260
Email: info@sperscientific.com

Be sure to include a description of the problem and your return address. Register your product online at www.sperscientific.com or return your warranty card within 10 days.



OPTIONAL ACCESSORIES

- 840090 Water Resistant Instrument Pouch
- 840092 Bench-Top Tripod
- 840093 Field Tripod

CONTENTS

INTRODUCTION	4
FEATURES	5
MATERIALS SUPPLIED.....	6
LCD DISPLAY	7
BASIC FUNCTIONS.....	8
MODE AND UNIT SELECTION	10
MEMORY	14
UVC SENSOR.....	17
BATTERY REPLACEMENT.....	19
MAINTENANCE.....	20
SPECIFICATIONS.....	21
OPTIONAL ACCESSORIES	22
WARRANTY	23

INTRODUCTION

The Sper Scientific UVC Light Meter (Model 850010) is a light-weight, portable instrument that measures damaging UV (ultraviolet) light in both natural and manmade environments.

The UV Light Meter measures short wave UV-C light for applications such as UV light fume hoods, UV sterilization, industrial glass and non-destructive testing.

You can use the meter almost anywhere to determine UV light intensity and avoid the harmful effects of overexposure.

SPECIFICATIONS

UV Range 1 (Low Illumination)	1 $\mu\text{W}/\text{cm}^2 \sim 9999 \mu\text{W}/\text{cm}^2$
UV Range 2 (High Illumination)	0.01 $\text{mW}/\text{cm}^2 \sim 40.00 \text{mW}/\text{cm}^2$
Resolution	1 $\mu\text{W}/\text{cm}^2$ and 0.01 mW/cm^2
Accuracy	$\pm 4\% \pm 1$ digit (at $23 \pm 5^\circ\text{C}$)
Wavelength	220 ~ 275 nm
Calibration Point	254 nm
Temperature Range	0 ~ 50°C
Meter Dimensions	6" x 2" x 1½" (145 x 55 x 40 mm)
Weight	4.4 oz (135 g)
Sensor Dimensions	Diameter = 35 mm H = 25.5 mm

MAINTENANCE

1. Dampen a sponge or soft cloth with soap and water to clean the housing.
2. Take care to prevent any liquids or moisture from getting inside the unit during cleaning.

FEATURES

- Tripod Mounting Socket
- High and low measurement range in milliwatts per square centimeter (mW/cm^2) or microwatts per square centimeter ($\mu\text{W}/\text{cm}^2$)
- Backlit LCD
- Magnetic Mount
- Simultaneous Display of Minimum, Maximum, Average and Recorded Data
- Zero Point Reset
- Hold Function
- 4 Digit Dual Display
- 20 Points Memory
- Automatic Measuring
- Low Battery Indicator

MATERIALS SUPPLIED

- Meter
- UV Probe
- Magnetic Mount
- 9 Volt Battery
- Instruction Manual
- Hard Carrying Case

BATTERY REPLACEMENT

This unit requires one 9 Volt battery. The  icon indicates a low battery. To replace:





1. Slide off battery cover from the back of the unit.
2. Insert a 9V battery ensuring correct polarity.
3. Replace battery cover.

UVC SENSOR

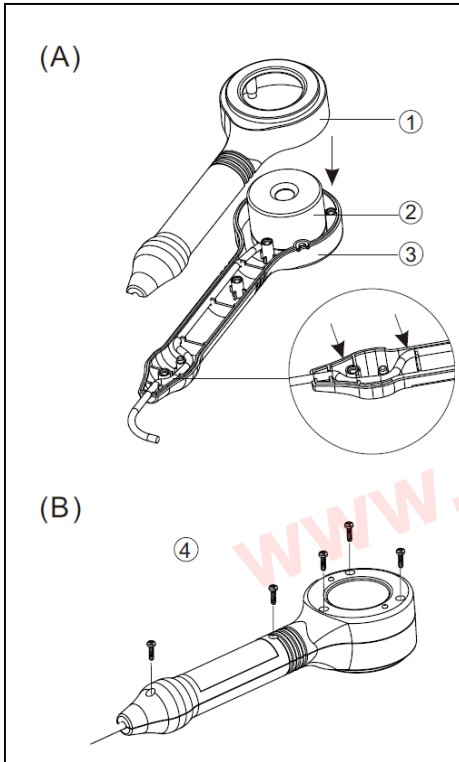
LCD DISPLAY

Portable Handheld Use



- 1. Upper casing  x 1
- 2. Sensor  x 1
- 3. Lower casing  x 1
- 4. Self-tapping screws  x 5

Note...
To avoid wearing the screw holes, limit the number of times you assemble and disassemble the probe.

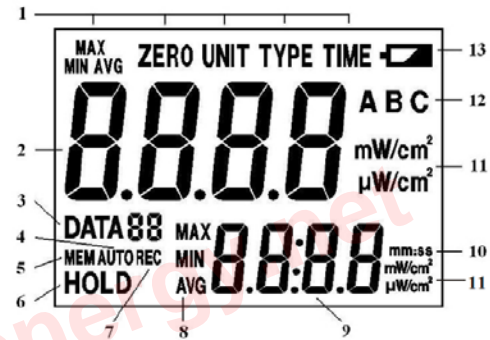

- 1. Mode
- 2. Primary Reading
- 3. Data Log
- 4. Auto Mode
- 5. Memory Review
- 6. Data Hold
- 7. Record
- 8. MAX/MIN/AVG
- 9. Secondary Reading
- 10. Time Unit
- 11. Unit of Measure
- 12. UV Type
- 13. Low Battery

BASIC FUNCTIONS

Power On/Off

1. Press and hold the **HOLD** button for 2 seconds to turn the meter **on**. All symbols on the LCD will appear for 1 second.
2. Press and hold the **HOLD** button for 2 seconds to turn the meter **off**. All symbols on the LCD will appear for 1 second. Release **HOLD** button.

Reading the LCD Display

1. The primary display indicates measurement value.
2. The secondary display indicates the advanced functions or data recording.

UVC SENSOR

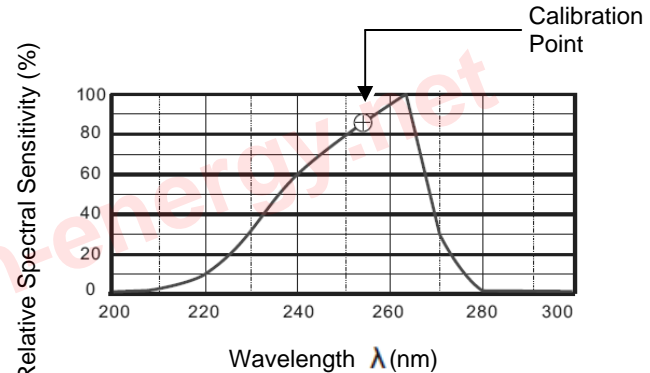

CAUTION:
THE UV SENSOR IS A SENSITIVE INSTRUMENT. TO PREVENT PREMATURE AGING AND THERMAL DESTRUCTION OF THE SENSOR, USE THE SENSOR FOR SHORT-TERM MEASUREMENT IN A SPLASH-PROOF ENVIRONMENT ONLY. THE HOUSING TEMPERATURE MUST NOT EXCEED 50°C. STORE IN A DRY ENVIRONMENT.

MEMORY

were automatically recorded, “AUTO” appears next to “MEM” during the recall.

- As you scroll through data points 0 to 20, the saved minimum, maximum, or average value appears on the secondary display.
- The “MAX”, “MIN” or “AVG” icon will appear on the bottom of the LCD next to the data point number to indicate whether the secondary display represents a maximum, minimum, or average value for that data point. If none of these icons appear, the value represents a stored value at that data point that is not a minimum, maximum or average value.

Clear Data

- Press **MODE** to select Zero Mode.
- Press **M** to clear all 20 stored data points.

BASIC FUNCTIONS

Meter Function Flow Chart

- Press **MODE** to choose the main function (MAX/MIN/AVG, Zero, Unit, Type or Time). MAX/MIN/AVG Mode is Normal Mode for this meter and has several sub-functions as indicated in the diagram below.

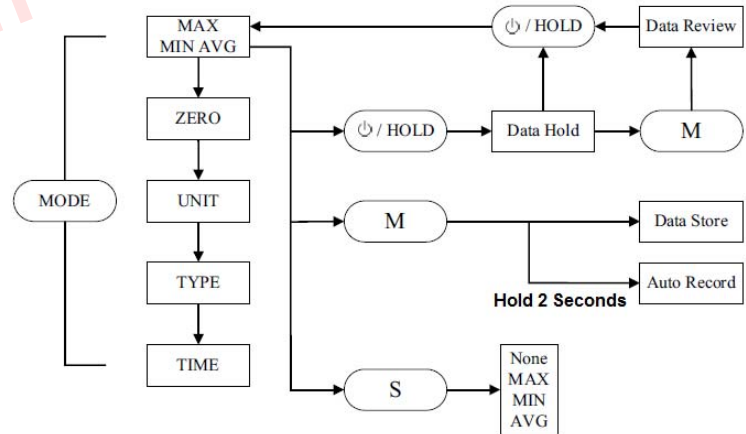

MODE AND UNIT SELECTION

Mode Selection

1. Press **MODE** continuously to cycle through MAX/MIN/AVG, Zero, Unit, Type, and Time Modes, respectively.

Maximum, Minimum and Average (Normal Mode)

1. Press **MODE** continuously to cycle through modes until you reach MAX/MIN/AVG.
2. The current measured value appears on the primary display.
3. To view minimum, maximum or average values of the current reading, press **S** continuously to select subcategory modes of None, Maximum hold, Minimum hold, and Average hold, respectively.
4. Maximum, minimum and average values will appear and freeze on the secondary display and will update only when a new maximum,

MEMORY

To Auto Record:

1. In Normal Mode, press and hold **M** for 2 seconds. "AUTO" appears next to "REC" on the LCD. As soon as the meter reaches 20 data points, the unit will turn **off**.

Recorded data includes: Irradiation intensity, Max/Min/Avg and unit of measure

2. Press **M** to cancel Auto-Record Mode.

Memory Recall

1. In Normal Mode, press **HOLD**.
2. Press **M** to enter Memory Mode. "MEM" will appear above "HOLD" on the LCD.
3. Press **S** to review data points 0 to 20 on the secondary display. Data point 0 indicates the set time interval between readings when in Auto-Record Mode. (Refer to "Interval Time Setting" section for instructions.) If the data

MEMORY

Manual Recording

In Normal Mode, press **M** to store the current value that appears on the primary display. The flashing DATA(01~20) icon stops flashing for 2 seconds and moves to the next storage location. (Refer to Maximum, Minimum and Average/Normal Mode on pages 10-11 for instructions on saving max, min, and avg values.)

Auto Recording

To utilize auto recording, you must first set an interval time for recording measurement values.

Interval Time Setting

1. Press **MODE** continuously to cycle through modes until you reach Time Mode.
2. Continuously press **S** to select an interval time for auto recording of 1, 2, 5, 10, 30 seconds or 1, 3, 5, 10 minutes.

MODE AND UNIT SELECTION

minimum, or average value is reached on the primary display. Then the secondary display updates automatically. The average value on the secondary display updates according to the detected maximum and minimum values of the current reading.

4. Press **M** to save the current, max, min, or avg value for each data point and the meter will move to the next data point. The stored data can hold either one current, max, min, or avg value for each data point.
5. Press **S** to reset.

Data Hold

1. While in Normal Mode, press **HOLD** to freeze the secondary display value. "HOLD" will appear on the bottom left corner of the LCD.
2. Press **HOLD** to cancel Hold Mode.

MODE AND UNIT SELECTION

Zero Adjustment

1. Press **MODE** continuously to cycle through modes until you reach Zero Mode.
2. Cover the sensor. If the main display has a reading other than zero, perform the zero adjustment.
3. Cover the sensor and press **S** to zero adjust. The secondary display indicates the adjustment value for your reference.
4. Press and hold **S** for 1 second to clear the adjustment value.

Note...

When the adjustment value is over 10 μW , the measurement value cannot be offset. The main display will show the above range reading, and the secondary display will show “-Err.” Repeat the zero adjustment procedure or contact Sper Scientific.

MODE AND UNIT SELECTION

5. In Zero Mode, press **M** to clear data points 0 to 20.

Unit Selection

1. Press **MODE** continuously to cycle through modes until you reach Unit Mode.
2. Press **S** to choose the unit of measure: $\mu\text{W}/\text{cm}^2$ or mW/cm^2 .

Type Selection

This function is reserved for use in future models.



www.eastern-energy.net

Email: info@ete.co.th