

Detachable Probe Sound Meter

840012

Instruction Manual

SPER
SCIENTIFIC LTD.



www.eastern-energy.net

Email: info@ete.co.th

CONTENTS

1. Introduction 3

2. Meter Description 3

3. Operating Instructions

 3-A Measuring Procedures 4

 3-B Hold 4

 3-C Rec. Max/Min..... 4-5

 3-D Max. Hold 5

 3-E Signal Output..... 5

 3-F Calibration 5

 3-G Precautions..... 5

 3-H Auto Shut Off..... 6

 3-I Battery Replacement..... 6

 3-J RS232 PC Serial Interface 6

4. Specifications 7

5. Frequency Weighting (A and C) Characteristics 8

6. Warranty..... 8



www.eastern-energy.net

Email: info@ete.co.th

1. INTRODUCTION

Features a detachable probe for easy replacement, and both RS232 computer interface and AC outputs. Also has A and C decibel frequency weighting scales, fast or slow time weighting, and two hold functions. Meets IEC651 and ANSI S1.4 specifications for a type 2 sound meter. Covers 30~130 dB in both Manual and Auto ranging scales with 0.1 dB resolution and an accuracy of ± 1.5 dB. Calibrate in compliance with OSHA using Acoustical Calibrator 840031 or equivalent. Has a fold-out easel back and a tripod screw.

2. METER DESCRIPTION

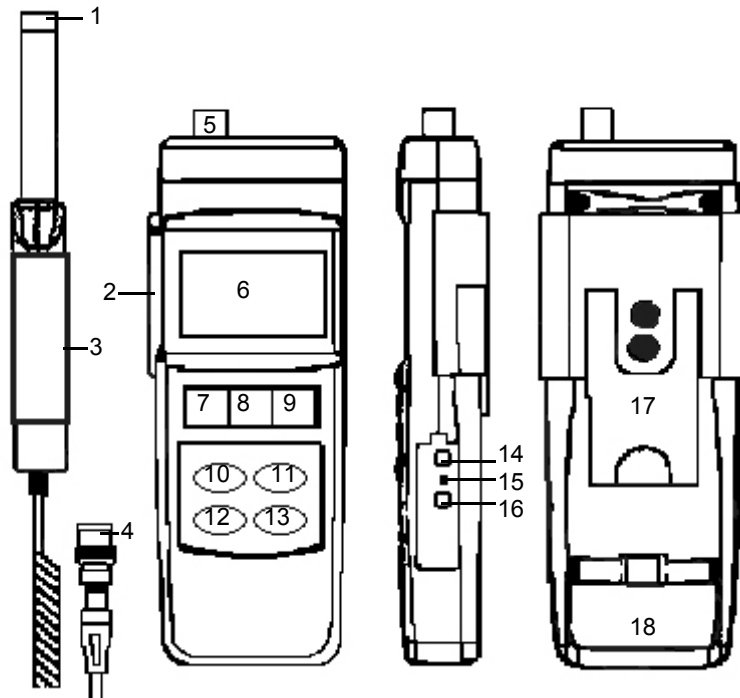

- | | | |
|-----------------|----------------------|---------------------|
| 1. Microphone | 7. Power Button | 13. Range Button |
| 2. Probe Holder | 8. Hold Button | 14. AC Output |
| 3. Probe Handle | 9. Rec./Max./Min | 15. Cal. Adjustment |
| 4. BNC Plug | 10. Max. Hold Button | 16. RS232 Output |
| 5. BNC Socket | 11. A/C Button | 17. Easel |
| 6. LCD display | 12. Fast/Slow Button | 18. Battery |

3. OPERATING INSTRUCTIONS

3-A. MEASURING PROCEDURES - See section 2, page 3 for button locations and descriptions.

- Connect the **BNC PLUG** (4) to the **BNC SOCKET** (5).
- Slide the **PROBE HANDLE** (3) into the **PROBE HOLDER** (2) (opt).
- Press the **POWER** (7) button to turn the unit on.
- The default mode is: Auto range, "A" frequency weighting and Fast time weighting.
- To change the frequency weighting, press the **A/C** (11) button.
- The "A" frequency weighting simulates human ear response. For an environmental sound measurement, select the "A" weighting.
- The "C" weighting approximates a flat response. Often, "C" is used to check the noise of machinery where the target sound level is already known.
- For more information about Frequency Weighting Characteristics, see the chart on page 8.
- Point the **MICROPHONE** (1) at the sound source.
- Use the auto range setting (default) or find the appropriate range using the **RANGE** (13) button.
- The manual selections are: 30~80dB, 50~100db, or 80~130db.
- If "- - -" is displayed, switch to another range. The sound level is displayed in decibels (dB).
- For general applications, press the **FAST/SLOW** (12) button to select "Fast", simulating the human ear's response time.
- The "Slow" setting is generally used to obtain an average of vibrating sound levels.
- Press the **POWER** (7) button to turn the unit off.

3-B. HOLD

- During the measuring procedure, press the **HOLD** (8) button to freeze the display.
- "HOLD" and the last measurement are displayed.
- Press the **HOLD** (8) button again to exit this function.

3-C RECORD MAXIMUM / MINIMUM MEASUREMENTS

- Press the **REC MAX/MIN** (9) button once to enter the recording mode. "REC" and the recorded values are displayed and continuously updated.
- Press the **REC MAX/MIN** (9) button as needed to view the recorded Max and Min values. "REC Max" and the maximum recorded value, or "REC Min" and the minimum recorded value are displayed.

- 4 -



www.eastern-energy.net

Email: info@ete.co.th

Note: The Max/Min values are frozen and not updated until the meter returns to recording mode.

- To return to recording mode, press the **HOLD** (8) button. "REC" is displayed without "Max" or "Min".
- To erase the recorded Max/Min values and exit the recording mode, press the **REC MAX/MIN** (9) button for at least 2 seconds.

3-D. MAX HOLD: (Holds the max measurement on the display.)

- Press the **MAX HOLD** (10) button, "P.H" appears on the LCD.
- Press the **MAX HOLD** (10) button again to exit this function.
- NOTE: Select auto range when using this function in slow varying noise environments. Select the appropriate manual range when using this function in pulsing noise environments.

3-E. AC OUTPUT

The 3.5 mm diameter **AC OUTPUT** (14) may be used to connect the unit to an external output device, such as an analyzer, recorder, or controller.

3-F. CALIBRATION

- The meter's **CAL** (15) adjustment is located on the side of the unit.
- Use Sper Scientific's 2 Pt. Acoustical Calibrator 850016 (or equivalent) to calibrate the unit in compliance with OSHA.
- Press the **POWER** (7) button to turn the unit on.
- Turn the acoustical calibrator on and place it onto the meter's **MICROPHONE** (1)
- To calibrate the meter to 94 dB, select the 50 ~ 100 dB range, FAST response, and "A" weighting.
- Use the calibration screw driver to gently turn the **CAL** (15) adjustment until the display reads 94.0.
- To calibrate the meter to 114 dB, select the 80 ~130 dB range, FAST response, and "A" weighting and turn the **CAL** (15) adjustment until the display reads 114 dB.

3-G. PRECAUTIONS

- Do not store or operate the unit in high temperatures or in high humidity for long periods.
- Keep the microphone dry.
- Do not force the **CAL** (15) adjustment, doing so may damage the mechanism and void the warranty.

3-H. AUTOMATIC SHUT OFF

After approximately 10 minutes without activity (with no buttons pushed), the meter will automatically shut off. To disable this feature, press the **REC** (9) button.

3-I. BATTERY REPLACEMENT



When the low battery icon is displayed, open the **BATTERY** (18) compartment to install a fresh 9V alkaline or heavy duty type battery. In-spec measurements may be made for several hours after the icon appears.

3-J. RS232 PC SERIAL INTERFACE

The instrument features **RS232** (16) output via a 3.5 mm terminal. The signal output is a 16-digit data stream that can be adapted to user-defined applications. A RS232 lead with the following connection is required to link the instrument with the PC serial interface.

Meter (3.5 mm jack plug)	PC (9W 'D' Connector)		
Center Pin	Pin 4	Pin 2	2.2 K resistor
Ground/shield.....	Pin 2	Pin 5	

The 16 digit data stream will be displayed in the following format:

D15 D14 D13 D12 D11 D10 D9 D8 D7 D6 D5 D4 D3 D2 D1 D0	
Each digit indicates the following status:	
D0	End word
D1 & D8	Display reading, D1 = LSD, D8 =MSD. Example: Display reads 1234, then D8 to D1 is 00001234
D9	Decimal Point (DP), position from right to left 0 = NO DP, 1 = 1 DP, 2 = 2 DP, 3 = 3DP
D10	0=Positive, 1=Negative
D11 & D12	Indicator for Display, dB = 17
D13	1
D14	4
D15	Start word

4. SPECIFICATIONS

Display	2" x 1.25" LCD (52x32mm), 5 digits with indicator.
Functions	dB (A & C Frequency Weighting), Response (Fast, Slow), Hold, Memory (Min/Max), Max. Hold, AC Output, RS232 Output
Measurement Range	30 -130 dB
Resolution	0.1 dB
Range Selector	30~80dB, 50~100dB, 80~130dB, 50dB on each step, over/under range indicator. Auto Range: 30 ~ 130dB
Accuracy	±1.5 dB
Frequency	31.5 Hz to 8,000 Hz
Microphone	Electric condenser microphone, Dia. .5" (12.7mm)
Response (Fast/Slow)	Fast (F): t = 200 ms Slow (S): t = 500 ms
Calibration VR	Built-in external calibration VR for easy calibration using a standard 94 dB calibrator.
Output Signal	AC output: AC 0.5 Vrms corresponding to each range step. Output impedance: 600 ohm
Output Terminals	RS232, AC, 3.5mm diameter jack
Operating Temp.	32~122°F (0~50°C)
Operating Humidity	Less than 80% RH
Power Supply	One 9V battery, heavy duty or alkaline type
Power Consumption	Approximately DC 6 mA
Weight	Weight: 8 oz (225 g) with battery
Dimension	Meter 10.6 x 2.7" x 1.1" (268 x 68 x 29mm). Probe 6.7" x 1" x .7" (170.5 x 24.5 x 19mm) Probe cord length: 78.7" (200cm)
Included Accessories	Windscreen, calibration tool, instructions, 9V battery, hard-shell foam-lined carrying case
Optional Services & Accessories from Sper Scientific	840012C NIST Traceable Cert. of Calibration 850016 2 Pt. Acoustical Calibrator 840057 RS232 Cable 840090 Water Resistant Instrument Pouch 850080 Software 840092 Bench Top Tripod 840093 Field Tripod

- 7 -



www.eastern-energy.net
Email: info@ete.co.th

5. FREQUENCY WEIGHTING (A and C) CHARACTERISTICS:

Meets IEC 651 type 2, calibrating input signal on 94 dB (31.5Hz to 8kHz).

Frequency	dB A	dB C	Tolerance dB
31.5	-39.4	-3	± 3
63	-26.2	-0.8	± 2
125	-16.1	-0.2	± 1.5
250	-8.6	0	± 1.5
500	-3.2	0	± 1.5
1k	0	0	± 1.5
2k	1.2	-0.2	± 2
4k	1.0	-0.8	± 3
8k	-1.1	-3	± 5

6. FIVE YEAR WARRANTY

Sper Scientific warrants this product against defects in materials and workmanship for a period of five years from the date of purchase, and agrees to repair or replace any defective unit without charge. If your model has since been discontinued, an equivalent Sper Scientific product will be substituted if available. This warranty does not cover damage resulting from accident, misuse, or abuse of the product. In order to obtain warranty service, ship the unit postage prepaid to:

SPER SCIENTIFIC LTD.
7720 East Redfield, Suite 7, Scottsdale, Arizona 85260
(480) 948-4448, www.sperscientific.com, info@sperscientific.com

Please Note: The defective unit must be accompanied by a description of the problem and your return address. Register online or return your warranty card within ten (10) days of purchase.

